

InfraCal[®] Filtometer

User's Guide



*InfraCal and InfraWin are registered trademark of Wilks Enterprise, Inc.
Copyright 2002 Wilks Enterprise, Inc., East Norwalk, CT*

www.WilksIR.com

Infracal[®] Filtometer Analyzer

Table of Contents

1. Infracal Filtometer Analyzer Overview	5
1.1 Introduction	5
1.2 Basic measurement concept	5
1.3. Filtometer Description and Physical Properties	6
1.3.1 Front operating panel	6
1.3.2 Back panel	7
1.3.3 Description of the controls	7
1.4. Filtometer Features	8
1.4.1. Internal Calibration	8
1.4.2 External Communication and Calibration	8
1.4.3 Recall Function/Averaging Results	8
1.4.4 Printing the Result	
2. Getting Started	8
2.1 Installation	8
2.1.1 Location	8
2.1.2 Power Requirements	8
2.1.3 Warm Up Time	9
2.2 Zeroing the Analyzer	9
2.2.1 Establishing Zero	9
2.2.2 Zero Check	9
3. Filtometer Calibration	9
3.1 Data Presentation	9
3.2 Selection of Suitable Calibration Standards	9
3.3 Calibration Considerations	10
3.4 Calibration Modes	10
3.4.1 Selecting the Calibration Mode	11
3.4.2 User Calibration Mode Procedure	11
3.4.3 Edit Calibration Mode Procedure	12
3.4.4 Collecting Calibration Data	12
3.4.5 Absorbance Versus Calibration Standard or Alternative Method	12
3.4.6 Entering Calibration Data into Edit Mode	12
3.5 Calibration Printing	13
4. Analyzing a Sample	13
4.1. Samples	13
4.2. Sample Analysis	13
5. Filtometer Sample Stages	14
5.1 Cuvette (CVH) Sample Stage	14
5.1.1. Cuvette Measurement Concept	15
5.1.2. Cuvette Measurement Considerations	15
5.2 HATR-T2 Sample Stage	16
5.2.1. HATR-T2 Measurement Concept	17

Infracal[®] Filtometer Analyzer

Table of Contents

5.2.2. HATR-T2 Considerations	17
5.2.3. Auto Evaporation Timer Programming	17
5.2.4. Timer Operation.....	18
5.3 IR Card Reader (CH) Sample Stage	18
5.3.1. Card Reader Measurement Concept	18
5.2.4. IR Card Reader Considerations.....	19
5.4 Sealed Cell Sample Stage	20
5.4.1 Sealed Cell Measurement Concept	20
5.2.4. Sealed Cell Considerations.....	20
6. Filtometer Specifications	20
6.1 External Power Requirements	20
6.2 Physical	21
6.3 Environmental	21
6.4 Electrical.....	21
6.5 Calibration.....	22
7. Filtometer Error Codes and Warning Codes.....	22
7.1 Error Codes.....	22
7.2 Warning Codes	23
8. Analyzer Communications Interface	23
8.1 Physical Connection	23
8.2 Communications Port Setup Parameters.....	24
8.3 Operation	24
8.4 Data Logging	25
8.5 Remote zero Balance Control.....	25
8.6 Remote Calibration Control.....	25
8.7 Error Status Command.....	26
9. Service and Technical Support	27

List of Figures

Figure 1 - The Infracal Filtometer: Front View of Analyzer.....	6
Figure 2: The Display and Control Panel.....	6
Figure 3: The Filtometer: Rear View.....	6
Figure 4: The Filtometer CVH Sample Stage: Front View.....	14

Figure 5: The Filtometer CVH Sample Stage: Top View14
Figure 6: Measurement of IR Absorption of a Sample with a Cuvette15
Figure 7: HATR-T2 Sample Stage: Front View.....16
Figure 8: The HATR-T2 Sample Stage: Top View16
Figure 9: Measurement of IR Absorption with an HATR-T2.....17
Figure 10: Measurement of IR Absorption of a Sample with an IR Sample Plate...18
Figure 11: The IR Sample Plate..... 19
Figure 12: The Filtometer CH Sample Stage: Top View..... 19

1. InfraCal Filtometer Overview

1.1 Introduction

InfraCal Filtometers are filter based infrared analyzers, providing the precision and accuracy necessary for repetitive quantitative mid infrared (mid IR) measurements in the laboratory, in the manufacturing plant, or in the field. The basic InfraCal Filtometer utilizes a fixed band pass filter/pyroelectric detector having one or two measurement wavelengths. However, up to 4 specific wavelengths can be incorporated into the detector (normally 3 analytical and 1 reference). Sampling options include transmission cells ranging from a fraction of a millimeter to 50 mm in path length, HATR-T2 sample plates available in several different materials including cubic zirconia, zinc sulfide and zinc selenide, and ATR In-Line Sensors. In all cases, infrared radiation is passed through a sample using an elliptical source mirror and focused on the detector package that contains filters to isolate an analytical and a reference wavelength. The result is calculated from the difference in the measured light absorbed by the sample at the analytical wavelength(s) and the reference wavelength.

Details for your sampling option and a procedure for sample preparation and analysis may be provided for your specific application.

1.2 Basic measurement concept

The InfraCal Filtometer makes use of the fact that many molecules absorb infrared energy at a specific wavelength and the amount of energy absorbed is proportional to the concentration. The energy collected at the analytical wavelength (I_A), is reduced when compared to the energy collected at the reference wavelength (I_R). The sample concentration is determined by a calculation of the logarithm of the ratio of the light transmission at the reference wavelength to the light transmission at the analytical wavelength (Beer-Lambert law). "A" equals the infrared absorbance. The Beer-Lambert law assumes a linear relationship between absorbance and concentration.

Beer-Lambert Law: $A = \log I_R/I_A$

Deviations from linearity are determined by obtaining absorbance values from known samples and an internal point to point calibration table is prepared (see Section 3) so that concentration in the desired units is directly presented on the display.

1.3 Filtometer description and physical properties

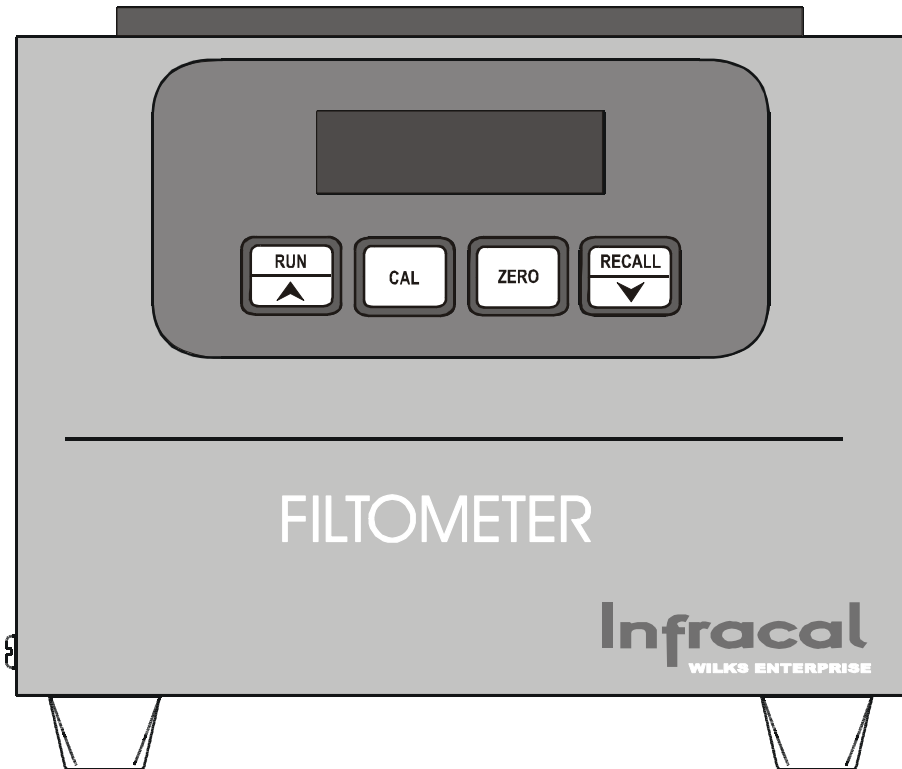

Figure 1: The InfraCal Filtometer: Front View

1.3.1. Front operating panel

The front panel consists of a 4 digit LED display and four labeled, touch-sensitive push button controls as illustrated in Figure 2. The LED display remains illuminated at all times while the analyzer is plugged in (switched on). When the instrument is not in use, and ready for use, the display may either show the result of the last analysis, or it may show *idLE*.

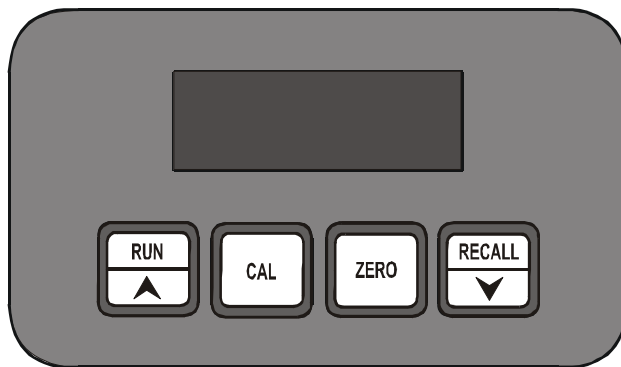

Figure 2: The Display and Control Panel

1.3.2. Back panel

The main power socket for the 12 Volt power supply is located on the back panel. The back panel also provides a standard nine pin, female DB9 connector for serial (RS232-C) data communications with the analyzer. This requires the use of a standard straight through serial data cable. See Section 7 for details of data communications with the Filtometer.

The back panel also contains the CE Mark designation indicating compliance with the codes for operation within the European Community countries, and also the analyzer serial number. The CAL lockout switch deactivates the front panel CAL button to keep the internal calibration table from being inadvertently changed or turned off. For calibration, the switch is ON (I). After calibration the switch may be moved to the locked position (O). Make a permanent note of the serial number, and quote this when contacting Wilks Enterprise with a service or warranty related issue.

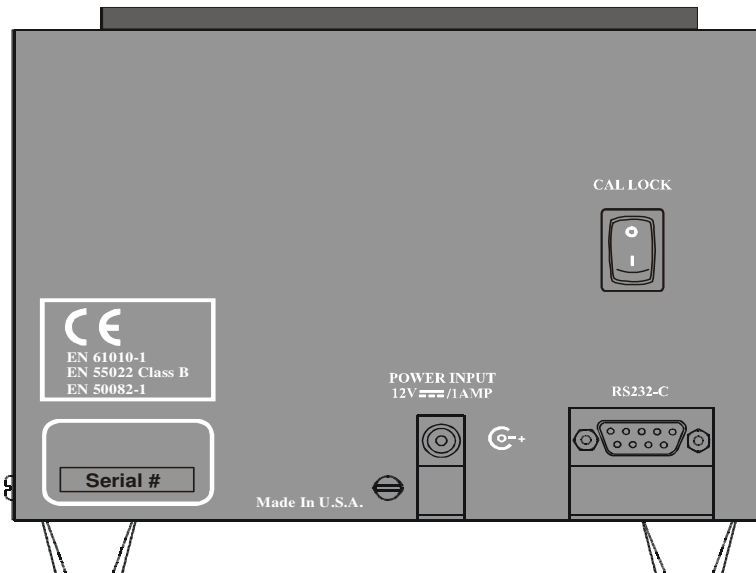

Figure 3: The Filtometer: Rear View

1.3.3 Description of the push button controls



RUN - initiates sample analysis (Section 4). Also used in the calibration mode (*CAL*) to record a calibration sample (Section 3).



UP arrow control - used to increase numerical values used in the calibration mode (*CAL*) (Section 3).



CAL – Hold for 2 seconds to select calibration type (*uSEr*, *Edit* or *oFF*). Also used to generate a new user calibration. Quickly press and release to print the last result.



ZERO - Hold for 2 seconds to zero balance the instrument (*baL* appears on display during operation (Sections 2). Also used to exit the calibration mode (*CAL*). For printer, quickly press and release to print the current calibration table.



RECALL - Quickly press and release to recall up to the last ten results (recall mode) or to display the average (averaging mode). Hold for 2 seconds to reset the printer sequence number.



DOWN arrow control - used to decrease numerical values used in the calibration mode.

1.4 Filtometer features

1.4.1 Internal Calibration:

The InfraCal Filtometer reads in relative absorbance units that are proportional to concentration. An internal microprocessor allows the user to enter a calibration in order to read in the desired units. The Filtometer contains three different user selectable calibration modes. These are *oFF*, *uSEr* or *Edit*. Section 3.4 explains the calibration functions in detail.

1.4.2 External Communication and Calibration:

The InfraCal Filtometer supports communications to a PC, printer or controller via an RS-232C asynchronous serial communications port. This capability allows for collection of sample measurement data and instrument control by a host computer. It also allows for multiple calibration tables if more than one table is being used with a single instrument.

InfraWin is a PC windows software package developed by Wilks Enterprise to interface to a PC. Some of the software features include collecting data, generating statistical summaries and graphs, storing multiple calibration tables, and remotely controlling the Filtometer. (For more information on InfraWin, contact either your local sales representative or Wilks Enterprise, Inc.)

Specification details for communication parameters are in Section 8.

1.4.3 Recall Function/Averaging Results

The Filtometer has the ability to store ten results for use with the averaging function or for local recall and display (see Section 4.2.1). Results may be data logged via the serial communications interface to a serial printer available as an accessory or to an external PC.

1.4.4 Printing the Result

An optional printer can be connected to the analyzer through the RS232C port located on the back. To print the result, momentarily press and release the **CAL** button. The result is printed on one line. The first number printed is a 5-digit sequence number. The sequence number is followed by the result. The remainder of the line contains the date, time and day of the week.

To reset the print sequence number press and hold the **RECALL** button until *PCLr* is displayed. The next result will print as sequence number 000001.

2. Getting Started

2.1 Installation

2.1.1 Location

The InfraCal Filtometer may be installed virtually anywhere. It is not affected by vibration and it can operate over a broad range of ambient temperatures (40° F, 4°C to 110°F, 45°C). With HATR-T2 sample stages the analyzer needs to be level (a bubble level and leveling feet are provided for this purpose).

2.1.2 Power Requirements

The Filtometer is powered from a 12 volts d.c. power source. A standard 12 volt power supply is provided with the analyzer, and this may be operated from any grounded a.c. outlet (line power requirements: 100 - 250 VAC, 50-60 Hz, 0.5-0.3 amps). When operating, the Filtometer consumes approximately 8 watts (0.67 amps). For field use, the instrument may be connected to other sources of 12

volt d.c. power, such as an external battery pack or the cigarette lighter output of an automobile (contact Wilks Enterprise for details). If the lighter output is used, the vehicle engine should be switched off during operation of the analyzer. Use with the engine running may result in the generation of a **bAtt** error code.

Plug in the external 12 volt supply to the power connector at the rear of the instrument. When plugged in, the instrument display will show **init** for a short time. Once the power-on initialization is complete, the instrument displays **idLE**. The Filtometer is now ready for use.

Note: the connector is polarized with the center pole positive. Failure to use the correct power supply or the correct cable can result in permanent damage to the Filtometer and may invalidate the warranty.

2.1.3 Warm up time

For normal operation, it is recommended that the instrument be allowed to warm up for 1 hour prior to use. However, the Filtometer is sufficiently stable after 15 minutes, and meaningful measurements may be obtained at this time. If the analyzer is used under the 1 hour warm-up time, check the zero prior to each run for best results. The longer warm-up time is recommended for critical measurements and for analyzer calibration. The Filtometer draws very little power and, unless operated from an external battery pack, it can be left on.

2.2 Zeroing the Filtometer

For initial set-up the Filtometer will need to establish zero using the following procedure. Once a zero has been established, subsequent zero checks should use the zero check procedure described in section 2.2.2.

2.2.1 Establishing Zero

Ensure that the sample holder is clean. Clean with appropriate solvent or cleaning solution.

- Present the zero sample or blank to the Filtometer.
- Press and hold the **ZERO** button until the display reads **bAL**. Release the button. A multiplier value to 3 decimal places will be displayed when zero is established. The actual value is only of interest when reporting problems to the factory.
- Press **RUN**. If the result is not within the desired range repeat the zero process.

2.2.2 Zero Check

The zero value is retained in permanent memory and is restored each time the instrument is powered up. It is recommended that the zero be checked and (if necessary) reestablished, on a daily basis.

- To check the zero value press the **RUN** button.
- If the result is not within the acceptable range, reclean the sample holder and verify that the zero sample is not contaminated.
- Check zero again.
- If the result is not within the acceptable range, reestablish the zero as described in 2.2.1

3. Filtometer Calibration

3.1 Data Presentation

The standard display format for the Filtometer is absorbance (**AbS**) which provides an absolute numerical result. Other formats are available, and these may be set for specific applications. The Filtometer must be

calibrated in the preferred data presentation mode. Changing the data presentation mode requires recalibration.

The different data presentation modes available for the InfraCal Filtometer are as follows:

Percent Mode (*PCt*): Calculated values are displayed to a single decimal place.

Decimal Mode (*dEC*): Calculated values are displayed to two decimal places.

Absorption Mode (*AbS*): An arbitrary scale related to the raw absorption of the sample.

Ratio Mode (*RAt*): A threshold based scale where a value defining an acceptable limit for maximum or minimum acceptable concentration is set to the value of 1.000. All values less than 1.000 indicate that the concentration is less than the threshold, while all values greater than 1.000 indicate that the concentration is greater than the threshold.

The Filtometer display format can be switched between modes by pressing and holding both the **CAL** and **ZERO** buttons for two seconds. Each time the **CAL** and **ZERO** buttons are pressed the display mode changes. Release both buttons and repeat until the desired mode is displayed. The display will read: *AbS* for absorption mode, *PCt* for percent mode, *dEC* for decimal mode, and *RAt* for ratio mode. Push run to return back to *idLE*.

3.2 Selection of suitable calibration standards

Select a set of carefully prepared samples covering the desired range for the analysis. An ideal calibration set may contain three to five samples. A maximum of 20 samples can be used. Ensure that the reference samples are fresh and accurately prepared. Select standards that cover the entire measurement range. The lowest concentration standard should measure at least 10 in the *oFF* mode. All successive standards should be spaced apart by at least 10 absorption units. Samples above the highest calibration standard will need to be diluted. *Do not use the zero sample used in the zero procedure as the first calibration standard.*

The InfraCal Filtometer may also be calibrated against an alternate method. For calibration against an alternate method obtain duplicate samples or if possible, test the same sample with the InfraCal and the alternate method. Data collected for this purpose should always be obtained with the calibration *oFF*. With a minimum of 10 data points, make a graph with InfraCal absorbance data vs. the alternate method values. Select 3 to 5 data points within the desired measurement range of operation and enter these calibration points into the InfraCal memory using the “edit” program that is described in section 3.4.3.

3.3 Calibration considerations

1. Allow the Filtometer to warm up at least one hour.
2. Always zero the Filtometer prior to calibration or collecting data for calibration analysis (see section 2.2).
3. Prepare a set of reference samples covering the desired range for the analysis. Ensure that the samples are accurately prepared. When comparing against an alternate method, collect enough data for a good representation of the measurement range.

3.4 Calibration modes

The Filtometer contains three different user selectable calibration modes. These are *oFF*, *uSEr* or *Edit*.

In the *oFF* mode the instrument measures Filtometer levels in arbitrary absorption units that are proportional to concentration levels. Higher values indicate increased levels of sample concentrations. This mode should be used to collect “raw” data when selecting reference samples to be used for user calibration as described in section 3.4.3.

Either the *uSEr* or the Edit modes can be used for calibration. The *uSEr* mode requires the user to enter in the calibration values at the time the calibration standard is presented to the Filtometer. The *uSEr* mode must be selected at the time of calibration.

The *Edit* mode allows the user to edit an existing calibration table or to create one from scratch, using absorption values obtained in the *oFF* mode. This is often the preferred method of creating a calibration table as an average of multiple sample measurements can be used to create the calibration points.

Note: There may be a fourth mode, FACT, if the customer requested a factory calibration.

3.4.1 Selecting the Calibration Mode

- Press the **CAL** button for two seconds, until **CAL** appears on the display. Press the **RECALL** button to display the active table, one of *uSEr*, *Edit* or *oFF*. Press and release the **RECALL** button repeatedly until the desired mode is displayed.
- Press the **ZERO** button to exit the calibration mode. *idLE* will be displayed.

3.4.2 User Calibration Mode Procedure

- Insure that the Filtometer has been properly zeroed (see Section 2.2) prior to calibration. *Do not use the zero sample used in the zero procedure as the first calibration sample.*
- Press the **CAL** button for two seconds, until **CAL** appears on the display. Press the **RECALL** button to display the active table, either *uSEr*, *Edit* or *oFF*. Press **RECALL** repeatedly to scroll through the above list until *uSEr* is displayed.
- Momentarily press and release the **CAL** button. The display will read **SA01**.
Caution: Pressing ZERO at this time will erase any existing calibration table.
- Insert the lowest calibration standard in the sample holder. Press the **RUN** button. *run* is displayed during the measurement cycle, followed by the raw absorption value.
- Scale the number upward by pressing the UP arrow (**RUN**) button or downward by pressing the DOWN arrow (**RECALL**) button until the actual concentration value is displayed.
- Momentarily press and release the **CAL** button to advance to the next standard. The display will read **SA02**. Repeat the above procedure for this sample. Continue to repeat for up to 20 standards. If a sample is run that produces a lower absorption value than the previous sample *Lo* will be displayed in place of the absorption value. Press any key to continue once the proper sample has been inserted in the sample holder.

NOTE: *If an error is made during the calibration process you can back up any number of samples to repeat the calibration starting from a given sample. Simply press and release the RECALL button when the sample number is displayed until the desired sample number is displayed. The sample in question plus all higher concentration samples must be run again to complete the calibration procedure.*

The calibration value should not be more than double the arbitrary absorbance value. If this is the case, contact a Wilks Enterprise technical representative and they will help with your calibration scaling. After the last sample has been run, press the **ZERO** button to exit the calibration mode. The display will read *idLE*. The calibration program has been permanently stored in memory.

3.4.3 Edit Calibration Mode Procedure

Calibration editing allows manual entry of calibration data. The user can collect several absorption results for each calibration point, compute the average value, and manually enter the results into the permanent calibration memory in the analyzer. Data collected for this purpose should always be obtained with the calibration *oFF*.

3.4.4 Collecting calibration data

Take several samples for each calibration standard or for each comparison to an alternate method and measure the absorbance value with calibration *oFF*(section 3.4.1). Average the results after discarding any obviously erroneous results. The results can be recorded as shown on the sample table below, or plotted graphically as a calibration curve. If using a curve, the values for absorbance versus calibration standard will be taken from the curve. The resulting plot can also be used to prepare a reference chart for users who prefer not to use the analyzer's internal calibration. Actual samples can then be measured and Filtometer concentration levels can be determined by converting absorption to actual values in units via the chart.

3.4.5 Absorbance Versus Calibration Standard or Alternate Method Table

(Absorbance Value)	(Calibration Standard in Desired Units)
A01 = _____	C01= _____
A02 = _____	C02 = _____
A03 = _____	C03 = _____
A04 = _____	C04 = _____
A05 = _____	C05 = _____
↓	↓
A20 = _____	C20 = _____
<i>n</i> (Number of calibration points or calibration standards) = _____	

3.4.6 Entering Calibration Data into the Edit Mode

- Press the **CAL** button for two seconds, until **CAL** appears on the display. Press the **RECALL** button to display the active table, one of *uSEr*, *Edi*t or *oFF*. Press **RECALL** repeatedly to scroll through the above list until *Edi*t is displayed.
- After **CAL** is pressed, the display will read *n*= for a short time, followed by the number of entries currently in the calibration table. Scroll to the desired number of calibration entries (0 - 20). **Selecting 0 will erase any existing calibration table.**
- Press **CAL** to proceed. **A01=** will be displayed followed by the current absorption value for the lowest calibration table entry. Scroll this to the desired absorbance value taken from the above chart. Press **CAL** again and the display will read **C01=** followed by the current Filtometer concentration value for the entry. Scroll this to the desired calibration standard value taken from the above chart.
- Continue to press **CAL** to step through all absorption and concentration values for the table size (*n*=) entered. Once all entries have been adjusted or created the display will read *idLE*. Note that all data values must be viewed (and optionally modified) to exit from the calibration editor.

3.5 Calibration printing

With the optional printer, the current calibration table can be printed by momentarily pressing and releasing the **ZERO** button when the analyzer is idle. The first line indicates which calibration is active followed by the date and time. The second line gives the headings for the calibration table that follows. **ABS** represents absorption and **CON** represents concentration. The table headings are followed by the balance value. One additional line is printed for each calibration table entry. The absorption and concentration values are given.

4. Analyzing a Sample

4.1 Samples

Unless the user ordered a factory calibration, the Filtometer will readout in relative absorbance units. If the user would like the readout in their desired units directly presented on the display, refer to section 3, analyzer calibration. The InfraCal Filtometer will provide reliable concentration measurements within the range specified for your application. When the maximum value is exceeded, a *notr* warning code (Section 7) indicates that the light throughput has fallen below an acceptable level, making the results unreliable. The measurement range can often be adjusted by either concentrating or diluting the sample.

4.2 Sample analysis

Sample preparation is unique to each application. For technical support, contact Wilks Enterprise.

- Present a prepared sample to the analyzer.
- Press the **RUN** button. The sample concentration will appear on the display within 20 seconds. If a calibration table has not been entered into the InfraCal Filtometer, the readout will be in relative absorbance units.

4.2.1 Averaged Results Display

The InfraCal Analyzer can display the average of up to ten sample measurements. To use the averaging mode, use the following procedure:

- Momentarily press the **RECALL** button once and ignore the result displayed.
- Analyze up to ten replicate samples using the measurement procedure described above.
- Momentarily press the **RECALL** button to display the average.

The next sample measurement will then start a new average accumulation.

The Analyzer alternatively can be configured to recall the last 10 measurements (from newest to oldest) in a circular fashion. First the Filtometer must be switched from the average mode (factory default) to the recall mode as described below. Once the recall mode is selected momentarily press the **RECALL** button repeatedly to display the previous results.

The Filtometer recall mode can be switched by pressing the **ZERO** button first, immediately followed by the **RECALL** button and holding both buttons for two seconds. The display will read *rCL* when switched to the recall mode. Repeat the procedure to return to average mode. The display will read *Ag*.

5. Filtometer Sample Stages

5.1 Cuvette (CVH) Sample Stage

The InfraCal Filtometer is available with an integrated cuvette holder and optics sensing system which accepts 10 mm quartz cuvette transmission cell. Custom sample cell holders can be provided for 1 mm and 5 mm, and 50 mm cells. The sample stage includes the infrared source (modulated) and detector system, positioned such that an elliptical energy beam is transmitted through the sample and focused directly on the detector-sensing window.

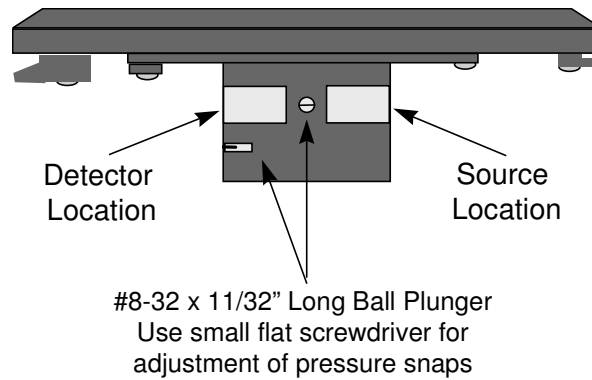

Figure 4: The Filtometer CVH Sample Stage: Front View

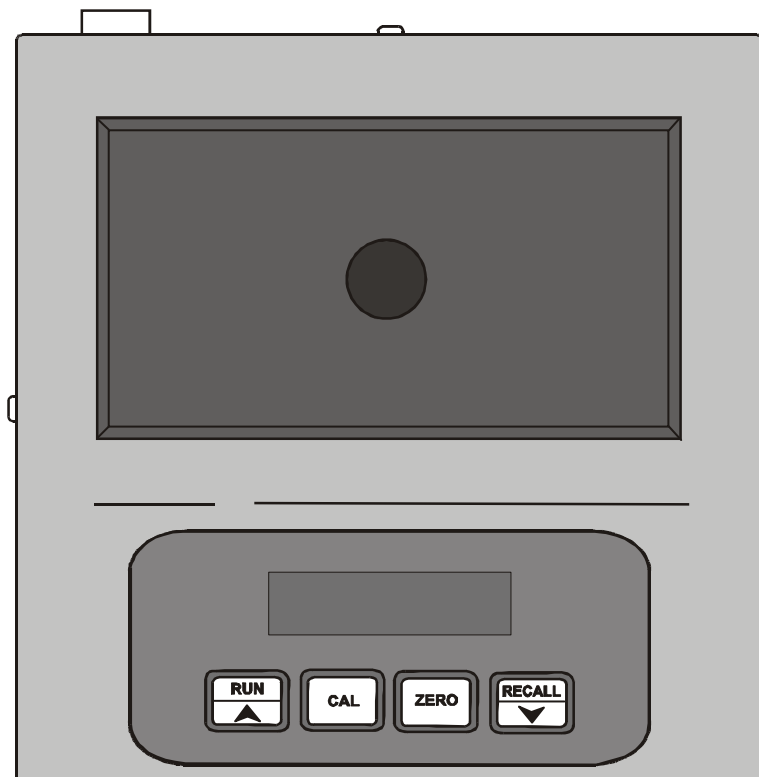

Figure 5: The Filtometer CVH Sample Stage: Top View

5.1.1 Cuvette Measurement Concept

With the CVH stage, a sample is placed directly in a quartz cuvette with a known path length. When the cuvette is placed in the sample stage a focused beam is passed through the sample and focused directly on the dual detector package. The energy collected at the analytical wavelength (I_A), is reduced when compared to the energy collected at the reference wavelength (I_R). The sample concentration is determined by a calculation of the logarithm of the ratio of the light transmission at the reference wavelength to the light transmission at the analytical wavelength (Beer-Lambert law) as shown in Figure 6. The Beer-Lambert law assumes a linear relationship between absorbance and concentration. Deviations from linearity are determined by obtaining absorbance values from known samples and an internal calibration table is prepared (Section 3) so that actual concentration is directly presented on the display.

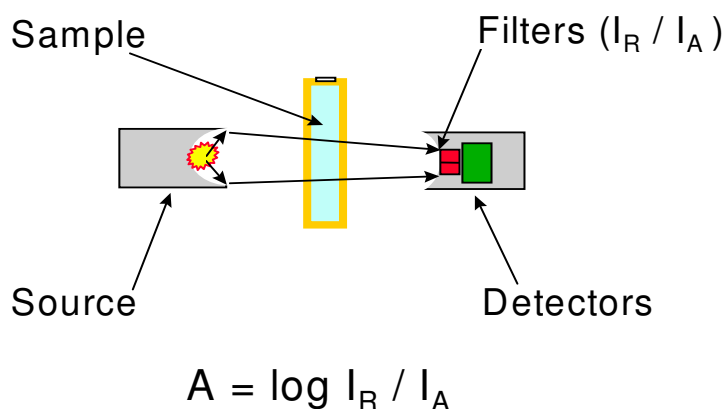

Figure 6: The Measurement of IR Absorption of a Sample with a Cuvette

5.1.2 Cuvette Measurement Considerations

1. All cuvettes must be made with infrared transmitting quartz windows (“Infracil” or equal).
2. Insert the cuvette in the holder with the frosted sides facing the front and back of the Analyzer. For optimum performance always insert with the same orientation. If multiple cuvettes are used they should be matched.
3. The cuvette holder accepts standard 10-mm quartz cuvettes. For higher or lower concentrations 50mm, 2 mm or 1 mm cuvettes may be used with the appropriate sample stage
4. Variation in cuvette size may require sample system readjustment. If the test cuvette series is either too tight or too loose for proper insertion and performance, the pressure snaps inside the sample holder will need minor adjustment.
 - 4.1 Disconnect the 12 volt power supply from the Analyzer.
 - 4.2 The sample stage is mounted with a spring clamp at the right end. To remove the sample stage, move the platform to the left and lift the right end. The whole assembly can now be lifted out of the InfraCal case. The cables do not have to be removed.
 - 4.3 With a slotted head screwdriver, turn the two (2) pressure snaps (clockwise tightens; counter clockwise loosens) 1/4 turns. Re-insert cuvette and “feel” for proper tightness (figure 4).
 - 4.4 Reinstall sample system when proper pressure snap tightness has been achieved for your cuvettes.

5. Always zero the Filtometer using a clean cuvette filled with clean zero sample prior to calibration or collecting data for calibration analysis.
6. Do not clean cuvettes with water. Always use a suitable solvent.

5.2 HATR-T2 Sample Stage

The InfraCal Filtometer, Model HATR-T2 is supplied with an integrated ATR cubic zirconia crystal and an integrated optics sensing system. Different crystal material can be custom ordered. The sample stage includes the infrared source (modulated) and detector system, positioned such that an elliptical energy beam is transmitted through the ATR crystal and focused directly on the detector-sensing window.

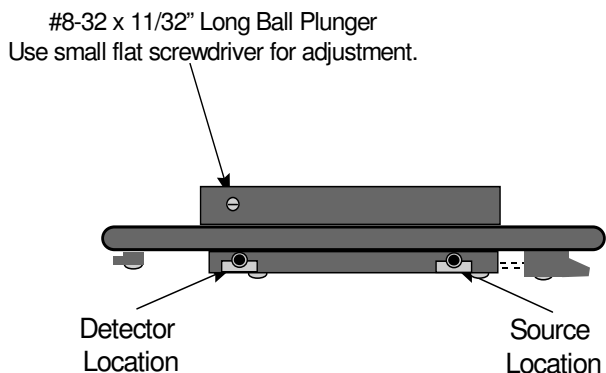

Figure 7: The HATR-T2 Sample Stage: Front View

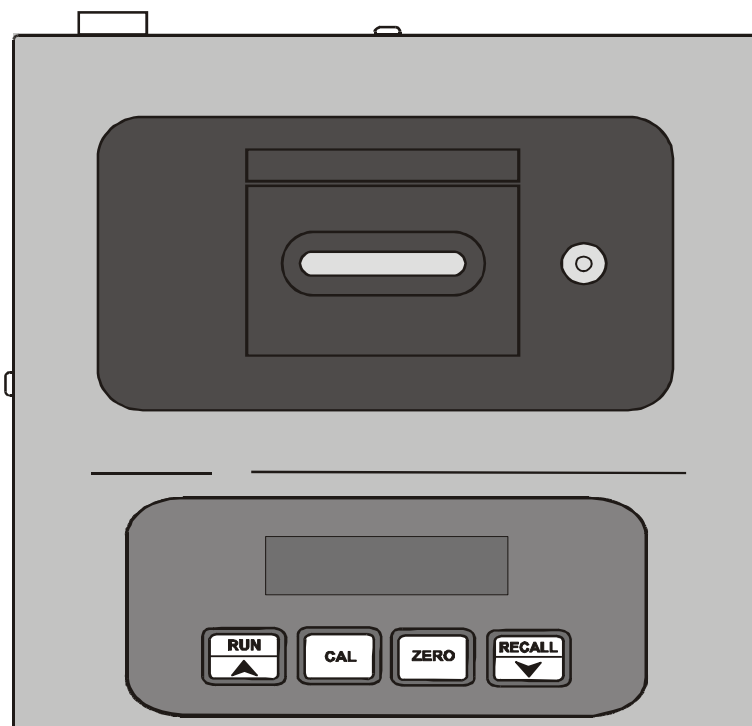

Figure 8: The Filtometer HATR-T2 Sample Stage: Top View

5.2.1 HATR-T2 Measurement Concept

The InfraCal Filtometer makes use of the fact that many molecules absorb infrared energy at a specific wavelength and the amount of energy absorbed is proportional to the concentration. The energy collected at the analytical wavelength (I_A). The sample concentration is determined by a calculation of the logarithm of the ratio of the light transmission at the reference wavelength (I_R) to the light transmission at the analytical wavelength (Beer-Lambert law). “A” equals the infrared absorbance. The Beer-Lambert law assumes a linear relationship between absorbance and concentration. Deviations from linearity are determined by obtaining absorbance values from known samples and an internal calibration table is prepared (Section 3 in the InfraCal Filtometer Manual) so that actual concentration is directly presented on the display.

Beer-Lambert Law: $A = \log I_R/I_A$

With the HATR-T2, an IR beam is internally reflected down the ATR crystal and the output is focused directly on the dual detector package. Since there is an evanescent wave that penetrates the sample at each internal reflection point, energy is absorbed at the analytical wavelength by the sample.

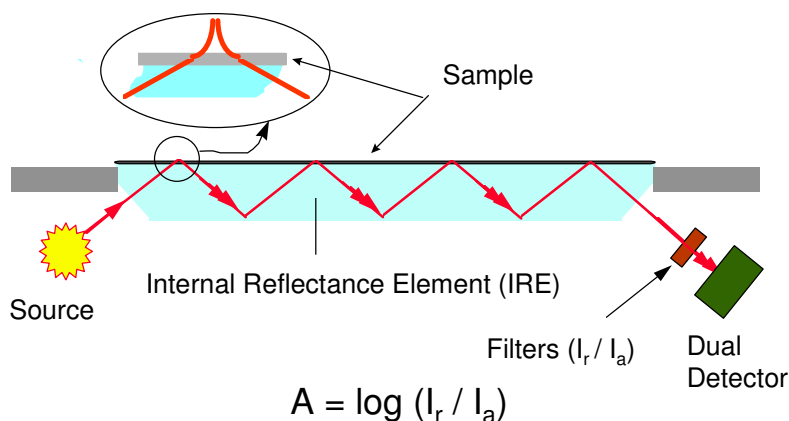

Figure 9: The Measurement of IR Absorption of a Sample with an HATR-T2

5.2.2 HATR-T2 Considerations

1. The InfraCal Filtometer must be placed on a flat, level surface. A bubble level and leveling feet are provided for this purpose.
2. Always zero the InfraCal Filtometer with the ATR crystal cleaned with the appropriate solvent. Dry with an anti-static wipe. Water is not recommended for cleaning since residue will affect the zero.
3. For samples that require the evaporation of a solvent use the auto evaporation timer described below.

5.2.3 Auto Evaporation Timer Programming

Press and hold the **RUN** button until the current timer value is displayed. The value is displayed as 1 or 2 digits in minutes and 2 digits in seconds, separated by a period (.). Release the **RUN** button once the current value (initially 0.00) is displayed. Use the up-arrow and down-arrow keys to scroll the timer to the desired value. The optimum time will vary with the type analysis and atmospheric conditions at the point of use. To zero the timer during programming, press the **ZERO** button. Once the desired time has been programmed press the **CAL** button. The display will read *idle*.

5.2.4 Timer Operation

The timer is disabled when programmed to zero (0.00). When the timer is non-zero, it is invoked during the normal **RUN**, **ZERO** and **CAL** functions.

Press and release **RUN** and the timer value is displayed. The timer will count down one second at a time. The dot separating minutes and seconds flashes to indicate the timer is counting. Once the timer reaches zero the display will read *run* during the sample measurement cycle followed by the result.

The **ZERO** function is initiated by pressing and holding the **ZERO** button until the timer value is displayed. The timer will count down as described above and **bAL** will then be displayed. On completion the balance result is displayed.

The timer is also invoked during calibration, each time the **RUN** button is pressed to analyze a sample.

To override the timer, press the **RUN** button a second time and the analyzer will go directly into the *run* cycle.

5.3 IR Card Reader (CH) Sample Stage

The InfraCal Filtometer can be supplied with a removeable IR Card Reader sample holder and an integrated optics sensing system which accepts reusable InfraCal Sample Plates and standard film holders. The sample stage includes the infrared source (modulated) and detector system, positioned such that an elliptical energy beam is transmitted through the sample plate crystal or film holder and focused directly on the detector-sensing window.

5.3.1 Card Reader Measurement Concept

With the CH stage, a sample is placed or deposited on an InfraCal Sample Plate or standard film holder. A focused beam is passed through the sample and focused directly on the dual detector package (figure 6). The energy collected at the analytical wavelength (I_A), is reduced when compared to the energy collected at the reference wavelength (I_R). The sample concentration is determined by a calculation of the logarithm of the ratio of the light transmission at the reference wavelength to the light transmission at the analytical wavelength (Beer-Lambert law) as shown in Figure 6. The Beer-Lambert law assumes a linear relationship between absorbance and concentration. Deviations from linearity are determined by obtaining absorbance values from known samples and an internal calibration table is prepared (Section 3) so that actual concentration is directly presented on the display.

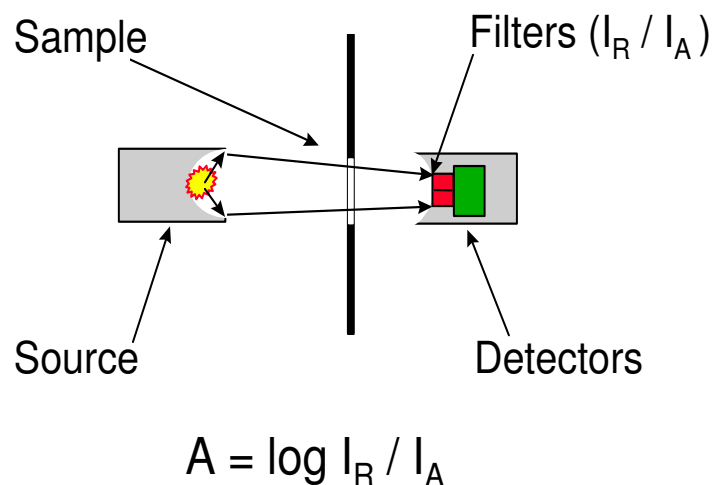

Figure 10: The Measurement of IR Absorption of a Sample with an IR Sample Plate

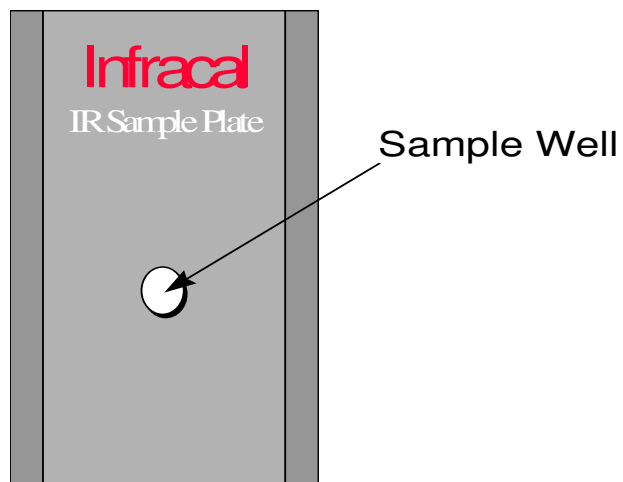

Figure 11: The IR Sample Plate

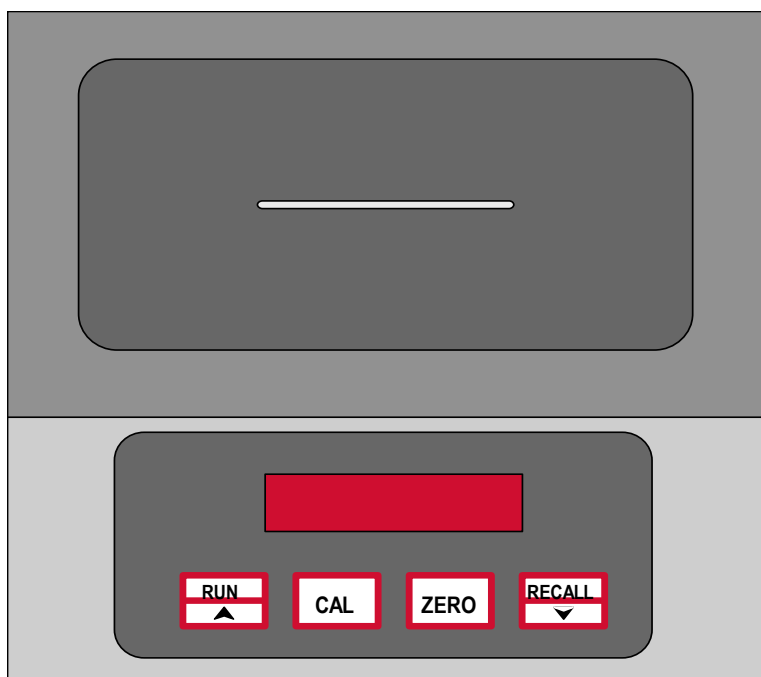

Figure 12: The Filtometer CH Sample Stage: Top View

5.3.2 IR Card Reader considerations

1. Only use IR sample plates supplied by Wilks Enterprise, Inc. made with infrared transmitting windows. Differences in transmission characteristics between plates may introduce quantitative errors when multiple plates are used. In this case, check each clean IR sample plate for zero value after zeroing on one of the plates. If the zero values are different, zero each plate prior to applying a sample for measurement.
2. Standard cardboard film holders are available from various sources and permit a film sample to be easily adhered for analysis.
3. For a sample that requires solvent to evaporate, place the IR plate on a flat, level surface when applying the sample.

4. Always zero the InfraCal Filtometer using a clean IR sample plate. The plate may be cleaned with a solvent such as methyl or ethyl alcohol or hexane. Dry with an anti-static wipe. Water is not recommended for cleaning since residues will affect the zero.

5.4 Sealed Cell Sample Stage

The Infracal Filtometer comes with a sealed cell sample holder that accepts standard fixed thickness or demountable cells as used with FTIR's. These are not supplied by Wilks Enterprise although they are easily obtainable from FTIR accessory supply houses. Wilks Enterprise can be contacted for suggested suppliers. The sealed cell comes in different pathlengths and different infrared transmitting windows predetermined for specific applications. The sample stage includes a modulated infrared source and detector system, positioned such that an energy beam is transmitted through the sample and focused directly on the detector-sensing window.

5.4.1 Sealed Cell Measurement Concept

With the Sealed Cell Sample Stage a sample is placed directly in a sealed cell with a known path length. When the sealed cell is placed in the sample stage a focused beam is passed through the sample and focused directly on the dual detector package. The energy collected at the analytical wavelength (I_A), is reduced when compared to the energy collected at the reference wavelength (I_R). The sample concentration is determined by a calculation of the logarithm of the ratio of the light transmission at the reference wavelength to the light transmission at the analytical wavelength (Beer-Lambert law) as shown in Figure 6. The Beer-Lambert law assumes a linear relationship between absorbance and concentration. Deviations from linearity are determined by obtaining absorbance values from known samples and an internal calibration table is prepared (Section 3) so that actual concentration is directly presented on the display.

5.4.2 Sealed Cell Considerations

1. All sealed cells must be made with infrared transmitting windows appropriate for the fixed filter wavelength selected for analysis.
2. Insert the sealed cell into the slots in the back of the samples holder.
3. Only use the recommended solvent or cleaner for cleaning the sealed cell.

6. Filtometer Specifications

6.1 External power requirements

The InfraCal Filtometer operates off external 12-volt power. The power sources can be either regulated DC power supplies or an external battery. This power can be provided by the user or by Wilks Enterprise, Inc. The suggested minimum requirement specifications for the 12 volt power source applied to the analyzer are described below:

Wall Supply Specifications:

Input:	100-250 VAC, 50-60 Hz, 0.5A
Output:	12 VDC, $\pm 1\%$, 25 Watts

Battery Supply Specifications:

Output: 14 VDC Maximum, 11 VDC Minimum

Load Specifications:
1.5 Amperes Peak

6.2 Physical

Dimensions: 6.5 in. x 6.5 in. x 5 in. (165 mm x 165 mm x 127 mm)
Weight: 4.5 lb. (2.0 kg.)
Control: Display (output) 4 digit 7 segment red LED,
5/8 in. character height
Connectors: User (input) 4 multi-function push-button switches
Power -- Switchcraft Model 760 plug or equivalent
Communications -- 9-pin D-Sub, female

6.3 Environmental

Temperature: Non-operating -- 0°F (-18°C) to 125°F (52°C)
Operating -- 40°F (4°C) to 110°F (45°C)
Humidity: Relative -- 10% to 60% non-condensing

6.4 Electrical

Noise: Rejection -- 60 dB minimum

Drift: Short term Ambient -- (< 1 Hr.) ± 0.3% of full scale
Long term Ambient -- (> 1 Hr.) ± 0.1% of full scale
Temperature -- ± 0.03% of full scale per degree C
Repeatability -- ± 0.1% of full scale

Response: On Delay -- 5, 10, 15 or 20 second factory-set intervals
Measure Time -- 5 seconds
Modes -- Local control or remote PC control

Resolution: Conversion -- 16 Bits (0.0015%)

Ranging: Digital Ranging -- 256 step automatic ranging
Analog Range -- 0 to 4.096 volts
Answer Range -- Absolute; 00 to 9999
Percent; 0.0 to 100.0%
Decimal; .00 to 99.99
Measure Range -- Dependant on sample concentration ratio

Measurement Accuracy: ± 1% of full scale
Measurement Repeatability: ± 0.1%, ±1 digit

Memory: Non-volatile memory for calibration and configuration data

6.5 Calibration

- Electronic zero balance adjustment
- Up to 20 point curve fitting calibration
- Modes: User Table
 Off
 Factory (special order)

7. Filtometer Error and Warning Codes

7.1 Error Codes

Internal Filtometer Analyzer diagnostics provide the following error code displays to aid the user in identifying potential problems and taking corrective action. If any error code is displayed, the user should reinitialize the instrument by depressing any key or temporarily removing and restoring external 12 volt power. If the error code persists, internal or factory service is required.

The following failure codes require factory service:

Er05 This error code indicates the Filtometer's internal +5 volt regulator is out of tolerance (+4.55 Vmin to +5.45 Vmax) for proper operation.

ErPA This error code indicates the Filtometer's internal +6.5 volt regulator is out of tolerance (+6.0 Vmin to +7.6 Vmax) for proper operation.

Er-A This error code indicates the Filtometer's internal -6.5 volt regulator is out of tolerance (-6.0Vmin to -7.6 Vmax) for proper operation.

ErEE This code indicates there is a diagnostic memory error internal to the Filtometer.

The following error code can be serviced by the user or by the factory:

ErSA This error code indicates the Filtometer's internal light source cannot be adjusted to the proper energy level required for instrument operation. This error may occur if the source cable has become disconnected or if the source is burned out. The user can observe the source best during initialization. The source is located on the right hand side of the sample surface window. The lamp should be modulating at high intensity while *init* is displayed. During *idLE* the intensity is significantly decreased. If this is not the case the user can repair this condition by removing the instrument cover and reconnecting the source cable (if disconnected) or by replacing the source. Otherwise, the instrument must be returned to the factory for service.

bAtt Signifies the external 12 volt source is out of the tolerance specified (+11 Vmin to +14 Vmax) for proper operation of the Filtometer.

If this error condition occurs when using a wall supply, the user can use a voltmeter to measure the DC level of the external power source. If the power supply is out of tolerance it must be replaced. If Wilks Enterprise supplied the power supply, return it to the factory for replacement. If the external power source has the correct 12 volt level and the Filtometer still indicates the **bAtt** error code, the analyzer should be returned to the factory for service.

If the external power source is a battery, the user should either replace the battery with a fully charged unit or recharge the low battery before proceeding.

7.2 Warning Codes

The following warning codes can be serviced by the user or by the factory:

notr This warning indicates the energy levels being received by the sample system detectors are below the minimum requirement for accurate signal processing. When this occurs, the measurement cycle is aborted and the ***notr*** warning is displayed instead of a result. This warning could occur if the lamp has failed. For this condition, the user should follow the service procedure specified for ***ErSA***. This warning could also occur in sample applications when the sample's transmission characteristics are close to 0%. For this condition, the user should reexamine the prepared sample.

If the ***notr*** warning occurs during a run cycle, a new measurement cycle can be initiated in the normal manner. If the warning occurs during a zero balance cycle, the analyzer zero remains unchanged from its previous value. If the warning occurs during the calibration procedure, the entire calibration procedure must be repeated.

8. Filtometer Communications Interface

The InfraCal Filtometer supports communications to a PC or other host via an RS-232C asynchronous serial communications port. This capability allows for collection of sample measurement data and instrument control by a host computer. The host can also maintain calibration tables and download them to the instrument as required. This is particularly useful when more than one table is being used with a single instrument.

InfraWin, a PC windows software package, developed by Wilks Enterprise, is designed to interface to the analyzer communications port as a host. The host software enhances the value of the analyzer by providing host methods for controlling modes and balances, collecting, labeling and storing data log results with pass/fail limits, calculating and viewing statistical information or presenting data log or calibration information in graphical formats. InfraWin provides enhanced methods for generating, storing and loading multiple calibration tables for Filtometer support. (For more information on InfraWin, contact either your local sales representative or Wilks Enterprise, Inc.)

Specification details for interfacing InfraWin or user customized host software is as follows:

8.1. Physical connection

The InfraCal Filtometer is connected to the external device via the 9-pin female DB9 connector located on the rear panel in the lower left-hand corner. The InfraCal Filtometer operates as a DCE device. To connect to a PC, a standard straight through 9 pin cable can be used, but only 3 wires are required.¹ The required signals are Transmit Data (TXD), Receive Data (RXD) and Ground (GND). The pinout is as follows:

<u>Function</u>	<u>Pin</u>
RXD	3
TXD	2
GND	5

¹ Systems with serial numbers lower than 10200 require a null modem cable or null modem adapter.

8.2. Communications port setup parameters

The port setup required by the InfraCal Filtometer is:

- 9600 baud
- 8 data bits, 1 stop bit
- No parity

8.3. Operation

The Filtometer accepts ASCII commands from the host and returns data as a response to certain commands or, in datalogging mode, on completion of a measurement cycle. All commands are two characters in length. Certain commands have parameters that follow the command. Parameters are separated by commas. All commands are terminated by a carriage return character. All data responses are comma separated ASCII fields, terminated by a carriage return character. The first field indicates the result type; the remaining fields are the result. Result types are 'B' for balance results, 'R' for run results or 'C' for calibration data. The result format is determined by the presentation mode and is identical to the LED display data. The Read Display Mode command returns a two character mode code. Alphabetic characters can be sent in upper or lower case. Response data is always upper case.

Command Set

Command	Description	Response Examples
RB	Read balance	B,1.025 B,0.865
RR	Read displayed result	R,27.5 R,315 R,1.873
RU	Run (same as RUN button)	None
RA	Run & display uncalibrated result	None
BA	Balance (same as Zero switch)	None
LR	Enable results datalogging	None
DR	Disable results datalogging	None
RM	Read display mode	MA, MP, MD or MR
MA	Set display mode to absolute	None
MP	Set display mode to percent	None
MD	Set display mode to decimal	None
MR	Set display mode to ratio	None
WB,<params.>	Set balance data	None
RC,<params.>	Read calibration table	See detailed description
WC,<params.>	Set calibration table	None
CM	Read Calibration Mode	CD, CE or CF
CD	Disable Calibration	None
CE	Enable User Calibration	None
CF	Enable Factory Calibration	None
ES	Return error status	E,0 E,2
RE	System reset	None
ID	Return firmware ID	2.02.06

8.4. Data logging

Data logging provides results output at the end of each RUN or BALANCE cycle. The results are output when datalogging is enabled both for functions initiated from the instrument control panel and functions initiated by the host. The format of the data returned after a RUN cycle is as shown for the RR command and is determined by the display mode. The format of the data returned after a BALANCE cycle is as shown for the RB command. The RA command allows the host to initiate a run cycle and datalog a result that is not adjusted by the calibration procedure. This can be used by an intelligent host resident calibration table generator.

8.5. Remote zero balance control

The instrument zero balance can be controlled via the communications port. The RB, WB and BA commands provide the necessary controls. This feature can be used to store multiple zero values for different operating conditions. This feature combined with the calibration controls described in the next section can be used to maintain multiple calibration curves when using the instrument for multiple applications.

The RB command will retrieve the current zero balance data. The WB command can then be used to reset the current zero balance to a previously recorded value. The WB data field is identical in format to the data returned in response to the RB command.

The BA command can be used to initiate a zero balance function under remote control. The operation is identical to initiating a zero balance from the instrument control panel. The user must insert the zero sample in the instrument prior to issuing this command. If datalogging is enabled the result will be returned on completion of the function. The data format is identical to the RB command response. The result can optionally be read with the RB command if datalogging mode is not used.

8.6. Remote calibration control

Calibration data can be retrieved or set under remote control. Due to the complexity of the calibration function (and the need to utilize multiple calibration standards) initial calibration can only be performed from the instrument panel. Another approach is to use the host to generate one or more calibration curves from uncorrected datalog results collected with the RA command. This technique is extremely useful if the user desires to generate a calibration curve based on an average result of several measurements from a lot of each calibration standard.

The RC command is used to retrieve the current calibration table. A Calibration table consists of zero to twenty entries. The RC command can take the following forms:

- RC Read entire calibration table
- RC,0 Read calibration table size
- RC,n Read a single calibration table entry, where n is the entry number.

The RC,0 command response is C,n where n is the number of calibration table entries from 0 to 20. If 0, the instrument is not calibrated. Otherwise, n is the number of calibration table entries.

The RC,n command response is C,n,x,y where n is the entry number as received, x is the raw measurement data as it appears on the display during calibration and y is the actual value as set by the user during calibration. The format is determined by the display mode (absolute, percent, or decimal). Calibration commands should not be used when in ratio mode since ratio mode does not use a calibration table. An RC command requesting data for a table entry number greater than the current table size returns erroneous data.

The RC command with no arguments returns the complete calibration table, one entry at a time starting with the table size information. The individual entries are then returned in numerical order up to the number of entries.

Read Calibration Table Example

Assume the instrument is calibrated in the absolute mode using three standards. Assume the calibration results were as follows:

<u>Entry</u>	<u>Measured</u>	<u>Actual</u>
1	15	30
2	26	50
3	33	70

The RC command will return the following:

```
C,0,3  
C,1,15,30  
C,2,26,50  
C,3,33,70
```

The RC,0 command will return C,0,3

The RC,2 command will return C,2,26,50

The WC command can be used to download calibration table data based on previously uploaded data or as determined by a host program. The command format is WC,n,x,y where the parameters are identical in format to the RC command. The parameters must match the current display mode. When using the WC command the table size and all necessary table entries should always be downloaded. Once all table entries have been downloaded the table size should be set.

Write Calibration Table Example

To download the calibration table described in the previous example, send the following commands:

```
WC,1, 15,30  
WC,2, 26,50  
WC,3, 33,70  
WC,0,3
```

8.7 Error status command

The Error Status (ES) command should return a value of 0. If a non-zero status is returned, a fatal error has occurred. The System Reset (RE) command can be used to restart the instrument in an attempt to clear the error condition. The host should then wait 30 seconds and reissue the ES command. If the error condition persists, service is required. See Section VI for details. The error codes are mapped to displayed error messages as follows:

<u>Error Code</u>	<u>Display Message</u>
1	ErSA
2	ErEE
3	Er05
4	ErPA
5	Er-A

9. Service and Technical Support

Your InfraCal[®] Filtometer may have been purchased either directly from Wilks Enterprise or from a local dealer or representative. If you have a technical question relative to the operation of the instrument or relative to the analysis, please contact Wilks Enterprise at the contact address provided below:

Customer Services Department
Wilks Enterprise, Inc.
25 Van Zant Street, Suite 8F
East Norwalk, CT 06855
USA

Telephone: (203) 855-9136
FAX: (203) 838-9868
E-mail: tech@wilksir.com

During the warranty period, Wilks Enterprise, Inc. offers free factory service for all failures that occur from normal instrument usage. The user is only required to cover the cost of shipping the instrument to the factory. After the warranty period, the user is required to cover the factory's cost of servicing plus all shipping charges. Normal one week turn around is offered for all InfraCal instruments that are returned to the factory for service. For users requiring faster service times, Wilks Enterprise also offers an advance replacement program that can respond to a user's needs with instrument replacement typically in less than 24 hours. For extended service contracts, advanced replacement programs, factory service charges or sample system installation procedures, please contact Wilks Enterprise, Inc. for details.

Wilks Enterprise, Inc. · 25 Van Zant Street, Suite 8F · East Norwalk, CT 06855 · www.WilksIR.com
Tel: 203-855-9136 · Fax: 203-838-9868 · info@wilksir.com · tech@wilksir.com